

SERVICE SIDE

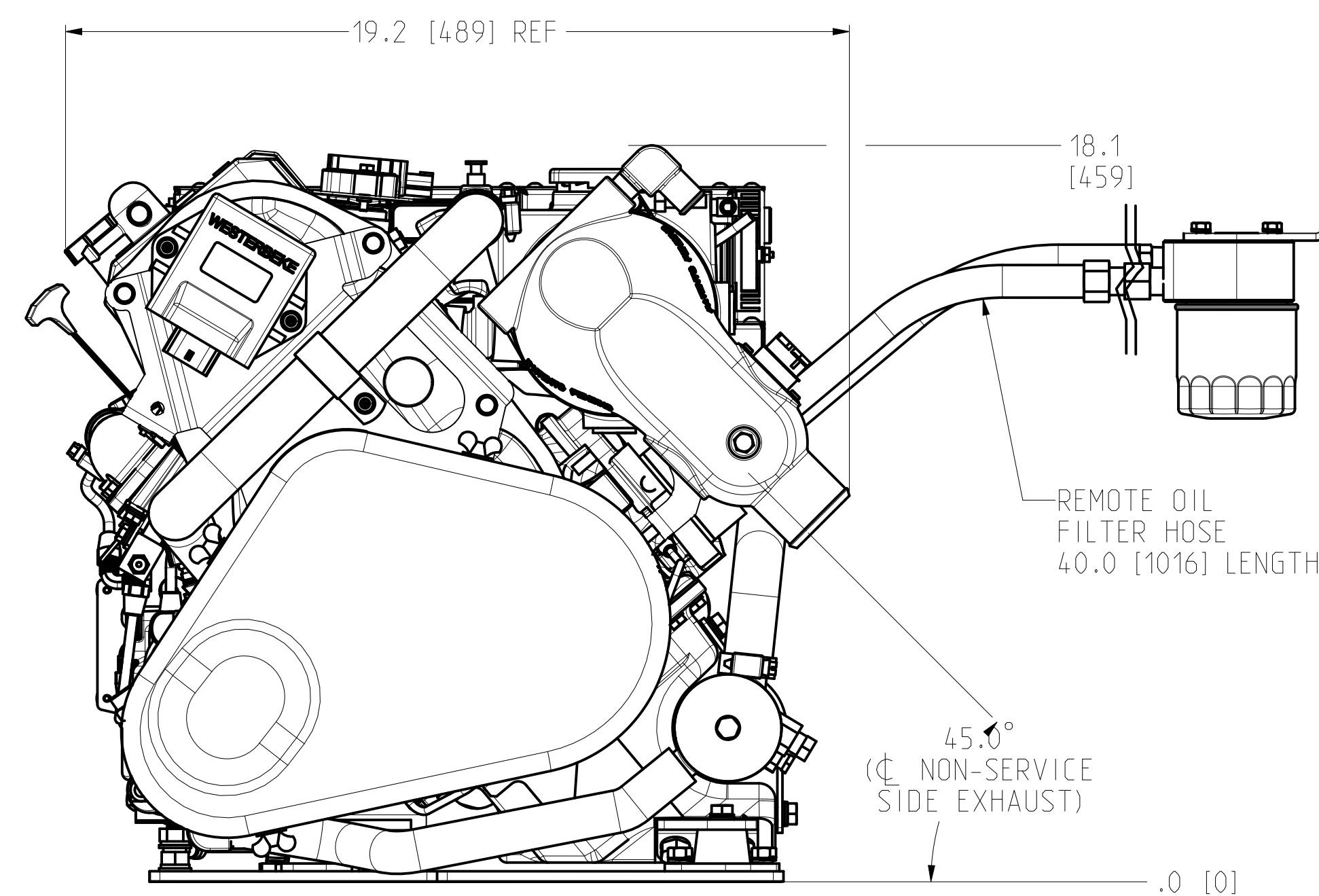

BELT END

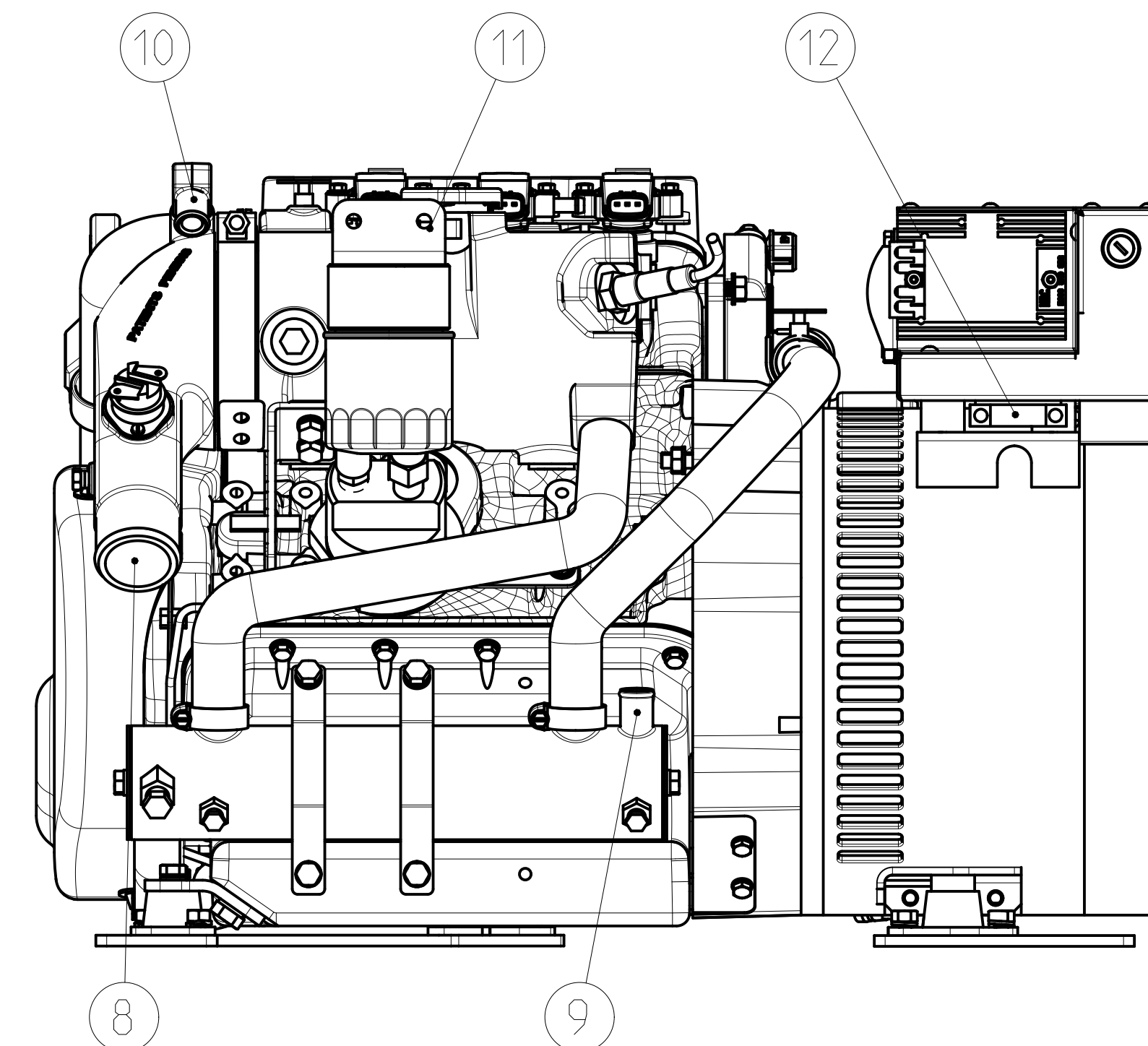

NON-SERVICE SIDE

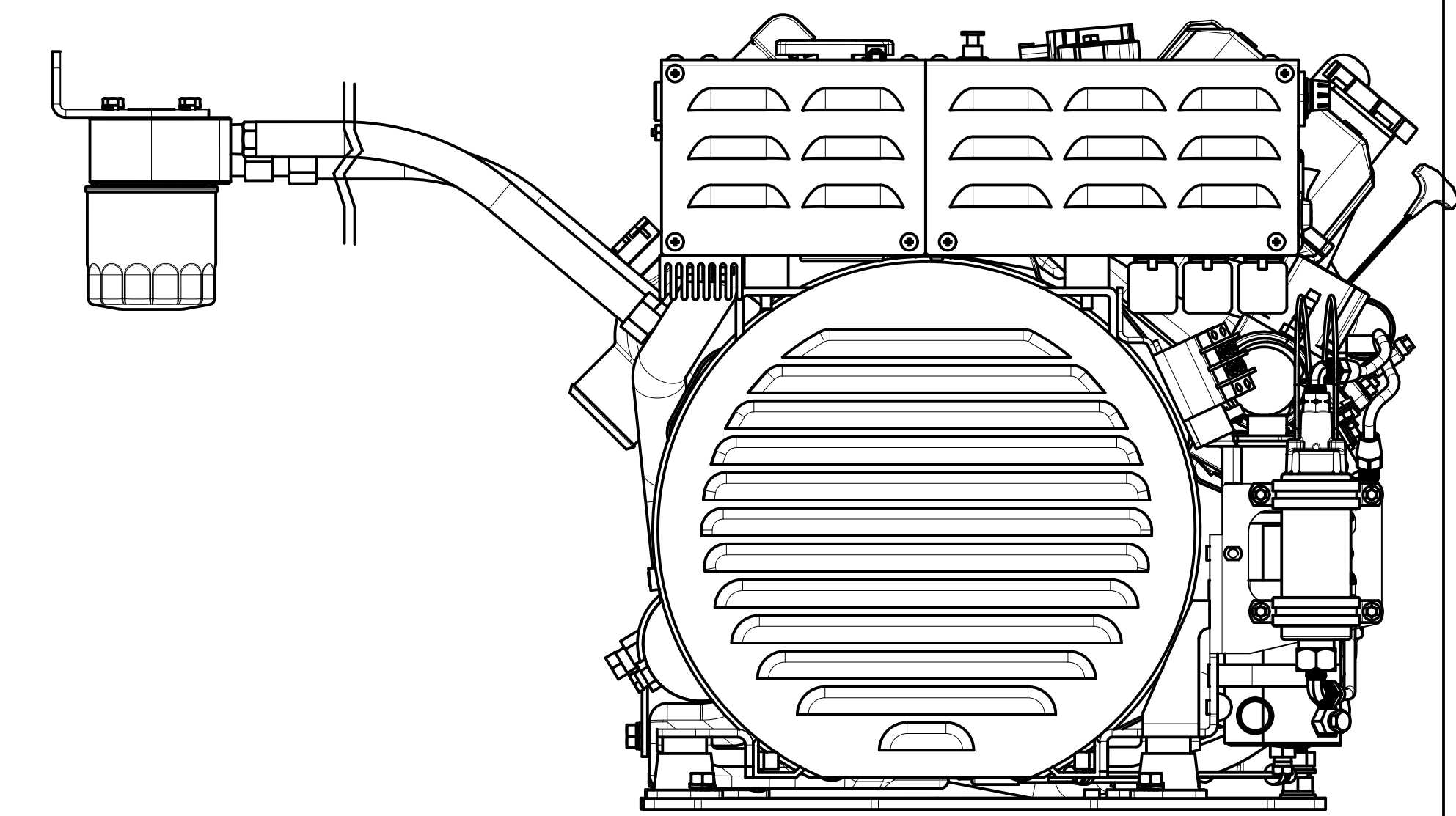

GENERATOR END

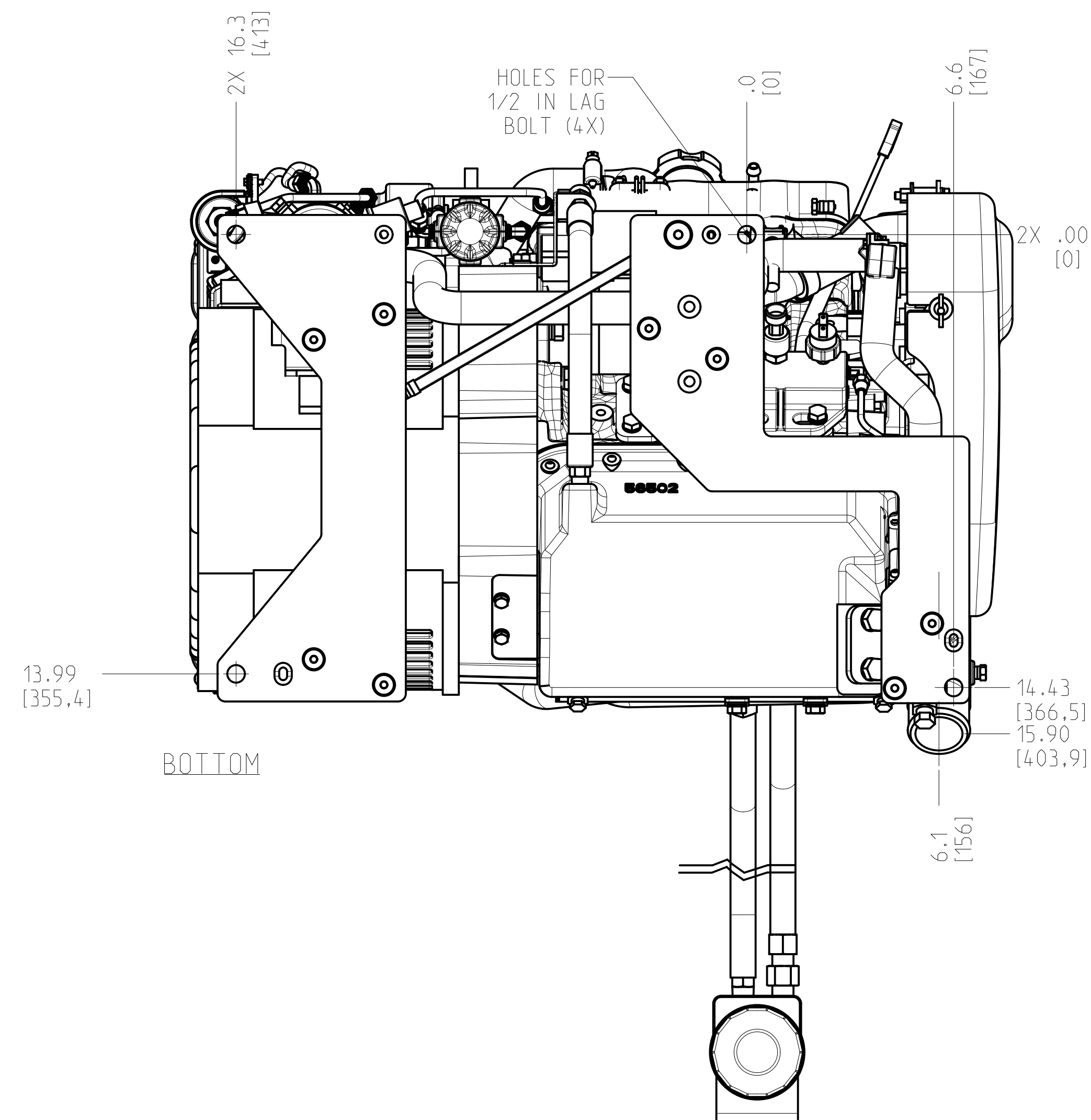

BOTTOM

REAR EXHAUST OPTION SHOWN

ITEM	CONNECTIONS
1	FIRE BOY
2	RAW WATER INLET, REQUIRES 3/4 IN ID HOSE TO CONNECT
3	FUEL LINE, REQUIRES 1/8-27 NPT MALE TO CONNECT
4	BATTERY (POS)
5	BATTERY (NEG)
6	REMOTE PANEL
7	A/C CIRCUIT BREAKER
8	WET EXHAUST, REQUIRES 2 IN ID HOSE TO CONNECT
9	RAW WATER OUTLET (TO SIPHON BREAK), REQUIRES 3/4 IN ID HOSE TO CONNECT
10	RAW WATER INLET (FROM SIPHON BREAK), REQUIRES 3/4 IN ID HOSE TO CONNECT
11	COOLANT OVERFLOW, REQUIRES 5/16 IN ID HOSE TO CONNECT
12	AC POWER

NOTES (UNLESS OTHERWISE SPECIFIED)  
 1. UNIT OF DIMENSIONS: INCH (MM)  
 2. TOLERANCE: ±.375 (9.5)

<b>TOLERANCES</b> UNLESS OTHERWISE SPECIFIED DECIMALS - ALL DIMENSIONS FRACTIONS - ALL DIMENSIONS		<b>WESTERBEKE</b> Engines & Generators		150 JOHN HANCOCK RD. EASTON, MA 02148 (508) 833-1671
INCHES: .0005 .0010 .0015 .0020 .0030 .0040 .0050 .0060 .0070 .0080 .0090 .0100 .0150 .0200 .0300 .0400 .0500 .0600 .0700 .0800 .0900 .1000 .1500 .2000 .3000 .4000 .5000 .7500 1.0000 1.5000 2.0000 3.0000 4.0000 5.0000 6.0000 8.0000 10.0000 15.0000 20.0000 30.0000 40.0000 50.0000 75.0000 100.0000	MILLIMETERS: .025 .050 .075 .100 .150 .200 .300 .400 .500 .750 1.000 1.500 2.000 3.000 4.000 5.000 7.500 10.000 15.000 20.000 30.000 40.000 50.000 75.000 100.000	TITLE: <b>DGINSTALL 5.0/4.2 MCGB</b>	MATERIAL: FINISH:	
DRAWN BY: <b>EP</b>	DATE CREATED: <b>01/19/2024</b>	APPROVED BY:	DATE:	FINISH:
SCALE: 0.312	SIZE:	DRAWING NUMBER: <b>E 58215</b>	REV:	SHEET: 2 OF 2

THIS DRAWING IS PROPRIETARY TO WESTERBEKE CORP. AND MAY NOT BE REPRODUCED OR TRANSMITTED IN ANY FORM OR BY ANY MEANS, ELECTRONIC OR MECHANICAL, WITHOUT EXPRESS WRITTEN PERMISSION.